

## PACKAGE LEAFLET

### CAPD/DPCA 19 Solution for Peritoneal Dialysis

**Read all of this leaflet carefully before you start using this solution.**

- Keep this leaflet. You may need to read it again.
- If you have further questions, please ask your doctor or your pharmacist.

#### **In this leaflet:**

1. What CAPD/DPCA 19 is and what it is used for
2. Before you use CAPD/DPCA 19
3. How to use CAPD/DPCA 19
4. Possible side effects
5. Storing CAPD/DPCA 19

#### CAPD/DPCA 19

##### Solution for Peritoneal Dialysis

- The active substances are sodium chloride, sodium-(S)-lactate, calcium chloride 2H<sub>2</sub>O, magnesium chloride 6H<sub>2</sub>O and glucose (as monohydrate).

1000 ml of CAPD/DPCA 19 solution contains sodium chloride 5.786 g, sodium-(S)-lactate 3.925 g, calcium chloride 2H<sub>2</sub>O 0.1838 g, magnesium chloride 6H<sub>2</sub>O 0.1017 g, glucose, anhydrous, 22.73 g, and up to 1.1 g/l fructose, equivalent to the electrolyte content of sodium 134 mmol/l, (S)-lactate 35 mmol/l, calcium 1.25 mmol/l, magnesium 0.5 mmol/l, chloride 102.5 mmol/l and glucose 126.1 mmol/l.

- The other ingredients are water for injections, hydrochloric acid and sodium hydroxide.

CAPD/DPCA 19 is supplied in two application systems, a “stay safe” and a “sleep safe”, in the following pack sizes (bags per carton):

#### *stay safe*

6 bags each containing 1500 ml  
4 bags each containing 2000 ml  
4 bags each containing 2500 ml  
4 bags each containing 3000 ml

#### *sleep safe*

2 bags each containing 5000 ml

#### **Marketing Authorization Holder:**

Fresenius Medical Care Deutschland GmbH, D-61346 Bad Homburg, Germany

#### **Manufacturer:**

Fresenius Medical Care Deutschland GmbH, Frankfurter Strasse 6-8, D-66606 St. Wendel, Germany

#### **Further Information:**

Distributed in ... by: ...

## **1. WHAT CAPD/DPCA 19 IS AND WHAT IT IS USED FOR**

This medicinal product is a solution for peritoneal dialysis.

CAPD/DPCA 19 is for end-stage chronic kidney failure of any origin requiring treatment with peritoneal dialysis.

## 2. BEFORE YOU USE CAPD/DPCA 19

### Do not use CAPD/DPCA 19:

- if you suffer from disorders of metabolism (lactic acidosis),
- if your potassium level is very low (severe hypokalaemia),
- if your calcium level is very low (severe hypocalcaemia),
- if the amount of your body fluid is reduced (hypovolaemia) or
- if your blood pressure is low (arterial hypotension).

Peritoneal dialysis must not be carried out if any of the following apply to you:

- if you have, or have had:
  - o recent abdominal surgery or injury to your abdomen including any history of operations with complications or adhesions
  - o abdominal burns
  - o perforation of your bowel (gut)
  - o inflammation of the skin of your abdomen, for example dermatitis
  - o inflammation of your bowel, for example Crohn's disease, ulcerative colitis, diverticulitis
  - o peritonitis (inflammation in your abdomen)
  - o abdominal fistulae (non-healing weeping wounds)
  - o hernias
  - o tumours in the abdomen or bowel
  - o obstruction in your bowel (this may be called an ileus)
- if you have:
  - o lung disease (particularly pneumonia)
  - o blood poisoning (sepsis)
  - o extreme weight loss (cachexia) and particularly when adequate protein intake is not possible
  - o very high levels of fat in the blood (hyperlipidaemia)
  - o uraemia (the accumulation of toxins in the blood caused by kidney failure) where it is known that peritoneal dialysis is not useful and is not an appropriate treatment
- if you are physically or mentally unable to carry out peritoneal dialysis as instructed by your doctor when on your own at home.

Due to the content of fructose, this medicinal product is unsuitable for you in case you have fructose metabolism disorders (hereditary fructose intolerance).

Should any of the above develop during peritoneal dialysis treatment, please consult your doctor who will decide how to proceed.

**CAPD/DPCA 19 is for intraperitoneal use only and must not be used for intravenous infusion.**

### Take special care with CAPD/DPCA 19:

You must tell your doctor if any of the following apply to you either before you receive your first peritoneal dialysis treatment or during dialysis, as they may affect the type of peritoneal dialysis solution you need:

- You are vomiting and/or have diarrhoea as this may cause a loss of electrolytes (salts).
- If you have an overactive parathyroid gland (hyperparathyroidism) your treatment should include the administration of calcium-containing phosphate binders and/or vitamin D to maintain your calcium and phosphate levels within the normal range.

- If your blood calcium levels are too low it may be necessary to take calcium-containing supplements and/or vitamin D or to use a peritoneal dialysis solution with a higher calcium concentration.
- If you are taking digoxin as your doctor will need to monitor your blood potassium level regularly.
- If you suffer from diabetes mellitus your doctor will need to monitor your blood glucose levels regularly and as a result your daily insulin dose or the number of tablets taken for your diabetes may need to be adjusted by your doctor.

The effectiveness of your dialysis will be monitored regularly by your doctor through assessment of your body weight, nutritional state, blood and other relevant tests.

The drained dialysis solution should be checked for clarity and volume. Cloudiness, which may or may not be accompanied by abdominal pain is an indicator of peritonitis and you should inform your doctor immediately (see Possible Side Effects below for further information).

A loss of proteins, amino acids, and water-soluble vitamins can occur during peritoneal dialysis. To avoid deficiencies an adequate diet should be ensured. Dietary supplements may be necessary and the need determined by your doctor.

### **Pregnancy**

If you are pregnant you should not start peritoneal dialysis before discussing it with your doctor.

### **Breast-feeding**

If you are breast-feeding you should not start peritoneal dialysis before discussing it with your doctor.

### **Driving and using machines:**

When used as prescribed CAPD/DPCA 19 does not impair your ability to drive or operate machines.

### **Taking other medicines:**

Please inform your doctor or pharmacist if you are taking or have recently taken any other medicines, including any medicines bought without a prescription. It is especially important to inform your doctor if you are a diabetic (using insulin or other blood sugar reducing drugs), if you are taking digoxin for your heart or drugs that increase the output of urine (diuretics – water tablets).

See also “Take special care with CAPD/DPCA 19”, above.

## **3. HOW TO USE CAPD/DPCA 19**

Your doctor will explain the treatment, the dose (i.e. bag volume) and the dwell time (the time that the solution will remain in the peritoneal cavity). The dose, number of exchanges and dwell time will vary according to your individual need.

If you have the impression that the effect of the solution is too strong or too weak, talk to your doctor.

### **Continuous ambulatory peritoneal dialysis (CAPD)**

#### Adults and the elderly:

A usual or common dose would be 2000 ml dialysis solution slowly infused into the peritoneal cavity using a permanent peritoneal dialysis catheter over a period of 5-20 minutes. After a dwell time between 2 and 10 hours the solution should be drained. This procedure should be carried out four times a day.

In large patients, and if any remaining kidney function is lost, or in patients who can cope with larger volumes, a volume of 2500-3000ml solution per exchange may be given.

If pain due to swelling of the abdomen occurs at the beginning of peritoneal dialysis, the volume of solution per exchange treatment should be temporarily reduced to 500-1500ml.

Children: In children, a dose of 500 - 1500 ml per treatment (30 - 40 ml/kg body weight) is recommended, depending on age, height and body weight.

## **Automated peritoneal dialysis (APD)**

If a machine (sleep.safe cycler) is used for intermittent or continuous cyclic peritoneal dialysis, larger volume bags (5000 ml) providing more than one solution exchange are used. The cycler performs the solution exchanges according to the prescription of your doctor stored in the sleep.safe cycler.

Dialysis using the prescribed doses should be performed daily. Peritoneal dialysis is a long term therapy involving repeated administration of single solutions.

### **Instruction for use**

To change the dialysis bag, it is of vital importance that you carefully follow the steps, which have been shown to you during training. The handling and cleaning methods described reduce the risk of infection. Only use a bag if the solution is clear and the container undamaged. Any unused portion of the solution is to be discarded.

### **Instruction for use of the stay safe system:**

Please refer to your training manual and the operating instructions for the heater tray/solution bag warmer.

First warm up the solution bag to body temperature. For bags with a volume up to 3000 ml this should be done using an appropriate heater tray. After warming the solution you can start with the exchange of the bags.

1. Check the solution bag (label, the expiry date and ensure that the solution is clear) – open the outer wrap and package of the disinfection cap.
2. Clean hands with an antimicrobial washing solution.
3. Place the DISC into the organiser (suspend solution bag from the upper hole of the infusion pole – unroll the line “solution bag-DISC” – place the DISC into the organiser – afterwards place drainage bag into lower holder of the infusion pole).
4. Place catheter adapter into the organiser.
5. Disinfect your hands and remove protection cap of the DISC.
6. Connect catheter adapter to the DISC.
7. Open catheter clamp – position “●” – outflow procedure starts.
8. Flush-position “●●” – flush of fresh dialysate to the drainage bag (approx. 5 seconds).
9. Inflow-position “○○●” – connection between solution bag and catheter.
10. Security step – position “●●●●” – automated closing of the catheter adapter with the PIN.
11. Disconnection (remove catheter adapter from DISC part) – screw catheter adapter to the new disinfection cap.
12. Close the DISC
13. Check the drained dialysate and dispose it.

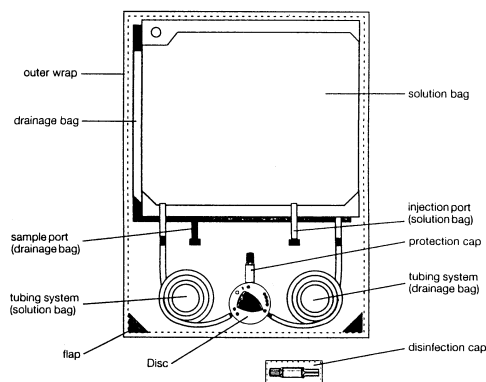

Instruction for use of the sleep safe system:

1. Prepare the solution
  - Check the solution bag (label, expiry date, clearness of the solution, bag and overwrap not damaged).
  - Place the bag on a solid surface.
  - Open the overwrap of the bag.
  - Wash your hands with an antimicrobial washing lotion.
  - Check whether the solution is clear and that the bag is not leaking.
2. Unroll tubing (1) of bag.
3. Remove the protection cap.
4. Insert connector in free sleep safe tray port.
5. The bag is now ready for use with the sleep safe set.

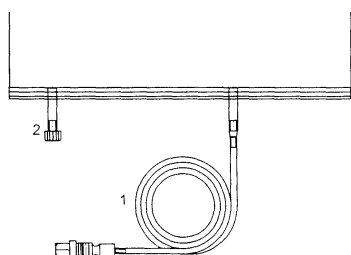

The cyclor checks the bar codes of the solution bags and gives an alarm when the bags do not comply to the prescription stored in the cyclor. After this check you can connect the tubing set to your catheter extension and start the treatment. The sleep safe solution is automatically warmed up to body temperature by the sleep.safe cyclor during the inflow into the abdominal cavity. Dwell times and selection of glucose concentrations are carried out according to the medical prescription stored in the cyclor (for more details please refer to the operating instructions of the sleep.safe cyclor).

If you have any problems or are uncertain how to proceed you should contact your doctor.

**If you use more CAPD/DPCA 19 than you should:**

If too much dialysate (solution) flows in, it can be easily drained into an empty bag. If, however, bag exchanges have been carried out too frequently, dehydration and/or disorders of blood electrolytes (salt imbalance) can occur and can be life-threatening. In this case please consult your doctor immediately.

**If you forget to use CAPD/DPCA 19:**

If you have forgotten an exchange of bags or have used too little solution, it is generally advisable to try to make up the prescribed daily dose (e.g. 4 x 2000 ml), in order to avoid a build up of body fluid, seen as swelling of the ankles and hands and/or shortness of breath or confusion. If this occurs contact your doctor immediately who will tell you exactly what to do.

**Effects when treatment with CAPD/DPCA 19 is stopped:**

If you stop treatment or your treatment is interrupted without letting your doctor know, or if you forget your treatment, accumulation of fluid in tissues and the lungs or other symptoms of urea poisoning will occur which would become life-threatening if not treated.

**4. POSSIBLE SIDE EFFECTS**

Like all medicines, CAPD/DPCA 19 can have side effects.

Side effects of the peritoneal dialysis treatment are frequently peritonitis - inflammation of the peritoneum characterised by the presence of a cloudy dialysate (solution) seen during drain out, abdominal pain, general malaise/generally feeling unwell, fever and, if untreated, generalised blood

poisoning - and inflammation around the catheter which can be recognised by redness, swelling, weeping, crusts and pain at the catheter exit site. If cloudy solution is seen on drain out you should seek medical advice immediately. The bag with the cloudy solution should be closed with a sterile cap and kept as it may need to be tested to determine the cause.

In addition the peritoneal dialysis treatment can cause abdominal swelling and a feeling of fullness, hernia, shoulder pain, shortness of breath due to the diaphragm being pushed upwards, diarrhoea and constipation. Disturbance or restriction of the in flow and out flow of dialysis solution into and out of the peritoneal cavity may also occur.

Undesirable effects of the dialysis solution may be fluid and electrolyte imbalance, which might include decreased potassium or calcium levels, an overactive parathyroid gland leading to possible bone disorders, symptoms of fluid build up (e.g. swelling, shortness of breath), dehydration (e.g. dizziness, muscle cramps), increased blood sugar levels, increased weight due to the continuous glucose (sugar) uptake and disorders of lipid (fat) metabolism. Increased heart beat (tachycardia), low blood pressure and high blood pressure have been reported.

If you notice any of these side effects or any adverse effects not mentioned in this leaflet, please inform your doctor or pharmacist immediately.

## **5. STORING CAPD/DPCA 19:**

Keep out of the reach and sight of children.

Do not store above 25°C. Do not refrigerate or freeze.

Do not use after the expiry date stated on the bag.

Do not use damaged bags or bags with cloudy content.

Any unused portion of the solution is to be discarded.

Date of last revision: September 2004